

# Regulating Pulse Width Modulator

## FEATURES

- 8 To 35V Operation
- 5V Reference Trimmed To  $\pm 1\%$
- 1Hz To 400kHz Oscillator Range
- Dual 100mA Source/Sink Outputs
- Digital Current Limiting
- Double Pulse Suppression
- Programmable Deadtime
- Under-Voltage Lockout
- Single Pulse Metering
- Programmable Soft-Start
- Wide Current Limit Common Mode Range
- TTL/CMOS Compatible Logic Ports
- Symmetry Correction Capability
- Guaranteed 6 Unit Synchronization

## DESCRIPTION

The UC1526 is a high performance monolithic pulse width modulator circuit designed for fixed-frequency switching regulators and other power control applications. Included in an 18-pin dual-in-line package are a temperature compensated voltage reference, sawtooth oscillator, error amplifier, pulse width modulator, pulse metering and setting logic, and two low impedance power drivers. Also included are protective features such as soft-start and under-voltage lockout, digital current limiting, double pulse inhibit, a data latch for single pulse metering, adjustable deadtime, and provision for symmetry correction inputs. For ease of interface, all digital control ports are TTL and B-series CMOS compatible. Active LOW logic design allows wired-OR connections for maximum flexibility. This versatile device can be used to implement single-ended or push-pull switching regulators of either polarity, both transformerless and transformer coupled. The UC1526 is characterized for operation over the full military temperature range of  $-55^{\circ}\text{C}$  to  $+125^{\circ}\text{C}$ . The UC2526 is characterized for operation from  $-25^{\circ}\text{C}$  to  $+85^{\circ}\text{C}$ , and the UC3526 is characterized for operation from  $0^{\circ}$  to  $+70^{\circ}\text{C}$ .

## BLOCK DIAGRAM

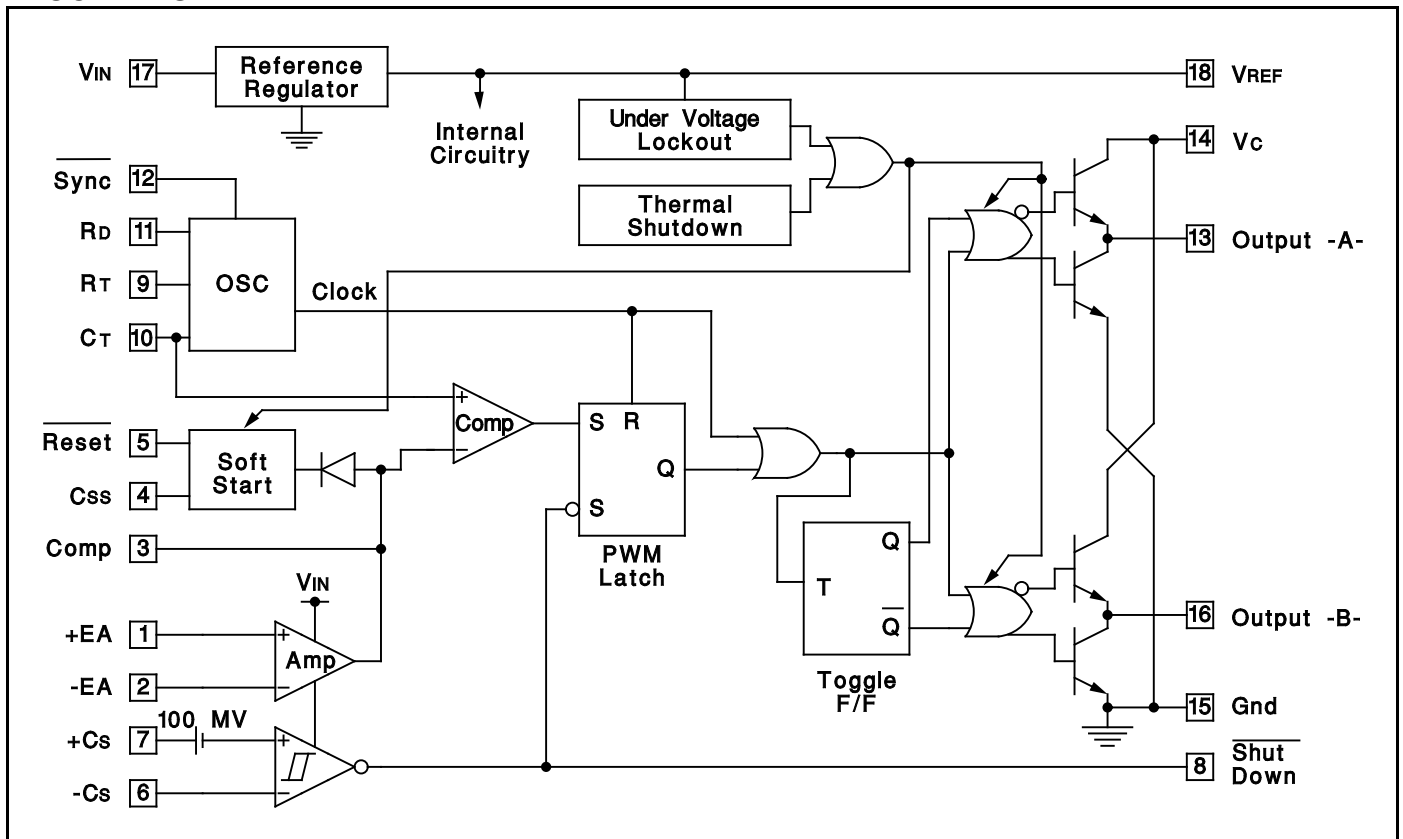

**ABSOLUTE MAXIMUM RATINGS** (Note 1, 2)

Input Voltage (+VIN)	+40V
Collector Supply Voltage (+Vc)	+40V
Logic Inputs	-0.3V to +5.5V
Analog Inputs	-0.3V to +VIN
Source/Sink Load Current (each output)	200mA
Reference Load Current	50mA
Logic Sink Current	15mA
Power Dissipation at TA = +25°C (Note 2)	1000mW
Power Dissipation at Tc = +25°C (Note 2)	3000mW
Operating Junction Temperature	+150°C
Storage Temperature Range	-65°C to +150°C
Lead Temperature (soldering, 10 seconds)	+300°C

Note 1: Values beyond which damage may occur.  
 Note 2: Consult packaging section of databook for thermal limitations and considerations of package.

**RECOMMENDED OPERATING CONDITIONS** (Note 3)

Input Voltage	+8V to +35V
Collector Supply Voltage	+4.5V to +35V
Sink/Source Load Current (each output)	0 to 100mA
Reference Load Current	0 to 20mA
Oscillator Frequency Range	1Hz to 400kHz
Oscillator Timing Resistor	2kΩ to 150kΩ
Oscillator Timing Capacitor	1nF to 20μF
Available Deadtime Range at 40kHz	3% to 50%
Operating Ambient Temperature Range	
UC1526	-55°C to +125°C
UC2526	-25°C to +85°C
UC3526	-0°C to +70°C

Note 3: Range over which the device is functional and parameter limits are guaranteed.

**CONNECTION DIAGRAMS**

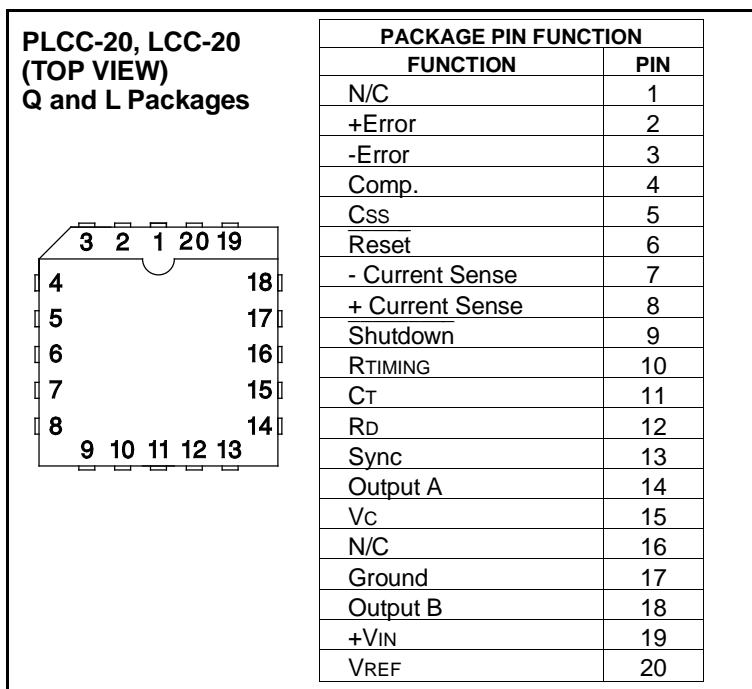
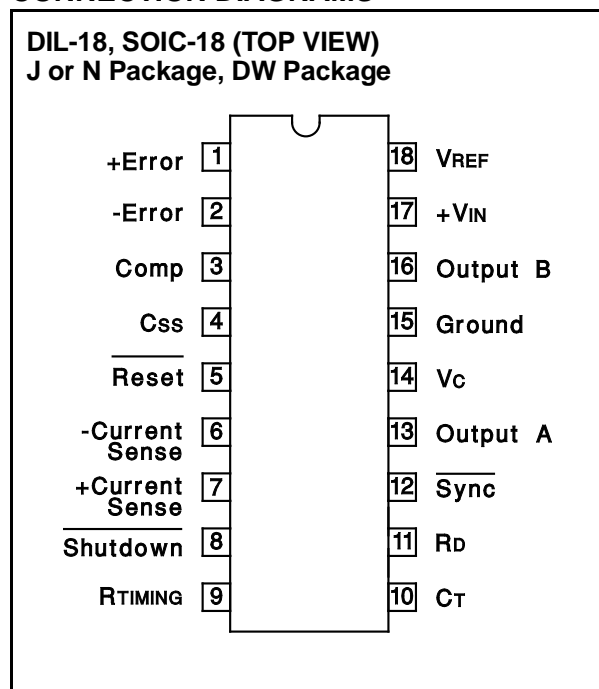

**ELECTRICAL CHARACTERISTICS:** +VIN = 15V, and over operating ambient temperature, unless otherwise specified, TA = Tj.

PARAMETER	TEST CONDITIONS	UC1526 / UC2526			UC3526			UNITS
		MIN	TYP	MAX	MIN	TYP	MAX	
<b>Reference Section (Note 4)</b>								
Output Voltage	TJ = + 25°C	4.95	5.00	5.05	4.90	5.00	5.10	V
Line Regulation	+VIN = 8 to 35V		10	20		10	30	mV
Load Regulation	IL = 0 to 20mA		10	30		10	50	mV
Temperature Stability	Over Operating Tj		15	50		15	50	mV
Total Output Voltage Range	Over Recommended Operating Conditions	4.90	5.00	5.10	4.85	5.00	5.15	V
Short Circuit Current	VREF = 0V	25	50	100	25	50	100	mA
<b>Under -Voltage Lockout</b>								
RESET Output Voltage	VREF = 3.8V		0.2	0.4		0.2	0.4	V
	VREF = 4.8V	2.4	4.8		2.4	4.8		V

Note 4: IL = 0mA.

**ELECTRICAL CHARACTERISTICS:** +VIN = 15V, and over operating ambient temperature, unless otherwise specified, TA = TJ.

PARAMETER	TEST CONDITIONS	UC1526 / UC2526			UC3526			UNITS
		MIN	TYP	MAX	MIN	TYP	MAX	
<b>Oscillator Section (Note 5)</b>								
Initial Accuracy	TJ = + 25°C		±3	±8		±3	±8	%
Voltage Stability	+VIN = 8 to 35V		0.5	1		0.5	1	%
Temperature Stability	Over Operating TJ		7	10		3	5	%
Minimum Frequency	RT = 150kΩ, CT = 20μF			1			1	Hz
Maximum Frequency	RT = 2kΩ, CT = 1.0nF	400			400			kHz
Sawtooth Peak Voltage	+VIN = 35V		3.0	3.5		3.0	3.5	V
Sawtooth Valley Voltage	+VIN = 8V	0.5	1.0		0.5	1.0		V
<b>Error Amplifier Section (Note 6)</b>								
Input Offset Voltage	Rs ≤ 2kΩ		2	5		2	10	mV
Input Bias Current			-350	-1000		-350	-2000	nA
Input Offset Current			35	100		35	200	nA
DC Open Loop Gain	RL ≥ 10MΩ	64	72		60	72		dB
HIGH Output Voltage	VPIN1-VPIN2 ≥ 150mV, ISOURCE = 100μA	3.6	4.2		3.6	4.2		V
LOW Output Voltage	VPIN2-VPIN1 ≥ 150mV, ISINK = 100μA		0.2	0.4		0.2	0.4	V
Common Mode Rejection	Rs ≤ 12kΩ	70	94		70	94		dB
Supply Voltage Rejection	+VIN = 12 to 18V	66	80		66	80		dB
<b>PWM Comparator (Note 5)</b>								
Minimum Duty Cycle	VCOMPENSATION = +0.4V			0			0	%
Maximum Duty Cycle	VCOMPENSATION = +3.6V	45	49		45	49		%
<b>Digital Ports (SYNC, SHUTDOWN, and RESET)</b>								
HIGH Output Voltage	ISOURCE = 40μA	2.4	4.0		2.4	4.0		V
LOW Output Voltage	ISINK = 3.6mA		0.2	0.4		0.2	0.4	V
HIGH Input Current	VIH = +2.4V		-125	-200		-125	-200	μA
LOW Input Current	VIL = +0.4V		-225	-360		-225	-360	μA
<b>Current Limit Comparator (Note 7)</b>								
Sense Voltage	Rs ≤ 50Ω	90	100	110	80	100	120	mV
Input Bias Current			-3	-10		-3	-10	μA
<b>Soft-Start Section</b>								
Error Clamp Voltage	RESET = +0.4V		0.1	0.4		0.1	0.4	V
Cs Charging Current	RESET = +2.4V	50	100	150	50	100	150	μA
<b>Output Drivers (Each Output) (Note 8)</b>								
HIGH Output Voltage	ISOURCE = 20mA	12.5	13.5		12.5	13.5		V
	ISOURCE = 100mA	12	13		12	13		V
LOW Output Voltage	ISINK = 20mA		0.2	0.3		0.2	0.3	V
	ISINK = 100mA		1.2	2.0		1.2	2.0	V
Collector Leakage	VC = 40V		50	150		50	150	μA
Rise Time	CL = 1000pF		0.3	0.6		0.3	0.6	μs
Fall Time	CL = 1000pF		0.1	0.2		0.1	0.2	μs
<b>Power Consumption (Note 9)</b>								
Standby Current	SHUTDOWN = +0.4V		18	30		18	30	mA

Note 4: IL = 0mA.

Note 5: FOSC = 40kHz (RT = 4.12kΩ ± 1%, CT = 0.1μF ± 1%, RD = 0Ω)

Note 6: VCM = 0 to +5.2V

Note 8: VC = +15V

Note 9: +VIN = +35V, RT = 4.12kΩ

## APPLICATIONS INFORMATION

### Voltage Reference

The reference regulator of the UC1526 is based on a temperature compensated zener diode. The circuitry is fully active at supply voltages above +8V, and provides up to 20mA of load current to external circuitry at +5.0V. In systems where additional current is required, an external PNP transistor can be used to boost the available current. A rugged low frequency audio-type transistor should be used, and lead lengths between the PWM and transistor should be as short as possible to minimize the risk of oscillations. Even so, some types of transistors may require collector-base capacitance for stability. Up to 1 amp of load current can be obtained with excellent regulation if the device selected maintains high current gain.

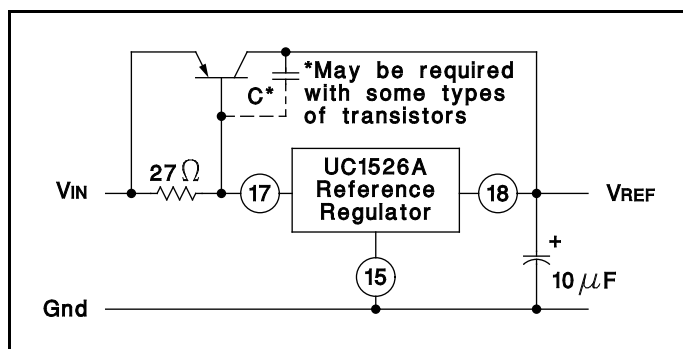

Figure 1. Extending Reference Output Current

### Under-Voltage Lockout

The under-voltage lockout circuit protects the UC1526 and the power devices it controls from inadequate supply voltage. If +VIN is too low, the circuit disables the output drivers and holds the  $\overline{\text{RESET}}$  pin LOW. This prevents spurious output pulses while the control circuitry is stabilizing, and holds the soft-start timing capacitor in a discharged state.

The circuit consists of a +1.2V bandgap reference and comparator circuit which is active when the reference voltage has risen to  $3V_{BE}$  or +1.8V at 25°C. When the reference voltage rises to approximately +4.4V, the circuit enables the output drivers and releases the  $\overline{\text{RESET}}$  pin, allowing a normal soft-start. The comparator has 200mV of hysteresis to minimize oscillation at the trip point. When +VIN to the PWM is removed and the reference drops to +4.2V, the under-voltage circuit pulls  $\overline{\text{RESET}}$  LOW again. The soft-start capacitor is immediately discharged, and the PWM is ready for another soft-start cycle.

The UC1526 can operate from a +5V supply by connecting the VREF pin to the +VIN pin and maintaining the supply between +4.8 and +5.2V.

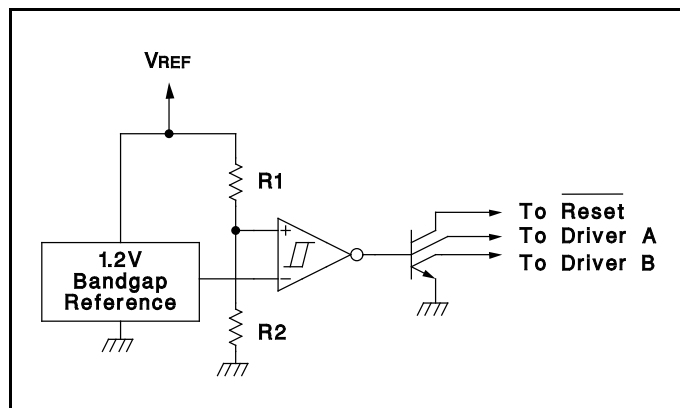

Figure 2. Under-Voltage Lockout Schematic

### Soft-Start Circuit

The soft-start circuit protects the power transistors and rectifier diodes from high current surges during power supply turn-on. When supply voltage is first applied to the UC1526, the under-voltage lockout circuit holds  $\overline{\text{RESET}}$  LOW with Q3. Q1 is turned on, which holds the soft-start capacitor voltage at zero. The second collector of Q1 clamps the output of the error amplifier to ground, guaranteeing zero duty cycle at the driver outputs. When the supply voltage reaches normal operating range,  $\overline{\text{RESET}}$  will go HIGH. Q1 turns off, allowing the internal 100mA current source to charge Cs. Q2 clamps the error amplifier output to  $1V_{BE}$  above the voltage on Cs. As the soft-start voltage ramps up to +5V, the duty cycle of the PWM linearly increases to whatever value the voltage regulation loop requires for an error null.

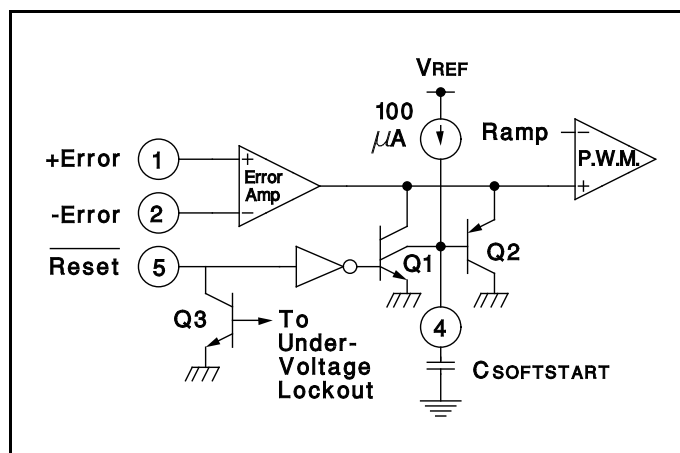

Figure 3. Soft-Start Circuit Schematic

### Digital Control Ports

The three digital control ports of the UC1526 are bi-directional. Each pin can drive TTL and 5V CMOS logic directly, up to a fan-out of 10 low-power Schottky gates. Each pin can also be directly driven by open-collector

## APPLICATIONS INFORMATION (cont.)

TTL, open-drain CMOS, and open-collector voltage comparators; fan-in is equivalent to 1 low-power Schottky gate. Each port is normally HIGH; the pin is pulled LOW to activate the particular function. Driving  $\overline{\text{SYNC}}$  LOW initiates a discharge cycle in the oscillator. Pulling  $\overline{\text{SHUTDOWN}}$  LOW immediately inhibits all PWM output pulses. Holding  $\overline{\text{RESET}}$  LOW discharges the soft-start capacitor. The logic threshold is +1.1V at +25°C. Noise immunity can be gained at the expense of fan-out with an external 2k pull-up resistor to +5V.

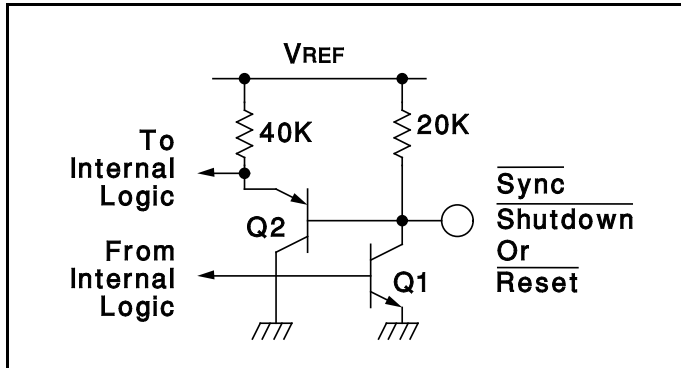

Figure 4. Digital Control Port Schematic

### Oscillator

The oscillator is programmed for frequency and dead time with three components:  $R_T$ ,  $C_T$  and  $R_D$ . Two waveforms are generated: a sawtooth waveform at pin 10 for pulse width modulation, and a logic clock at pin 12. The following procedure is recommended for choosing timing values:

1. With  $R_D = 0$  (pin 11 shorted to ground) select values for  $R_T$  and  $C_T$  from Figure 7 to give the desired oscillator period. Remember that the frequency at each driver output is half the oscillator frequency, and the frequency at the +Vc terminal is the same as the oscillator frequency.
2. If more dead time is required, select a large value of  $R_D$ . At 40kHz dead time increases by 400ns/ $\Omega$ .
3. Increasing the dead time will cause the oscillator frequency to decrease slightly. Go back and decrease the value of  $R_T$  slightly to bring the frequency back to the nominal design value.

The UC1526 can be synchronized to an external logic clock by programming the oscillator to free-run at a frequency 10% slower than the sync frequency. A periodic LOW logic pulse approximately 0.5 $\mu$ s wide at the  $\overline{\text{SYNC}}$  pin will then lock the oscillator to the external frequency.

Multiple devices can be synchronized together by programming one master unit for the desired frequency and then sharing its sawtooth and clock waveforms with the slave units. All  $C_T$  terminals are connected to the  $C_T$  pin of the master, and all  $\overline{\text{SYNC}}$  terminals are likewise connected to the  $\overline{\text{SYNC}}$  pin of the master. Slave  $R_T$  terminals are left open or connected to  $V_{REF}$ . Slave  $R_D$  terminals may be either left open or grounded.

### Error Amplifier

The error amplifier is a transconductance design, with an output impedance of 2M $\Omega$ . Since all voltage gain takes place at the output pin, the open-loop gain/frequency characteristics can be controlled with shunt reactance to ground. When compensated for unity-gain stability with 100pF, the amplifier has an open-loop pole at 800Hz.

The input connections to the error amplifier are determined by the polarity of the switching supply output voltage. For positive supplies, the common-mode voltage is +5.0V and the feedback connections in Figure 6A are used. With negative supplies, the common-mode voltage is ground and the feedback divider is connected between the negative output and the +5.0V reference voltage, as shown in Figure 6B.

### Output Drivers

The totem-pole output drivers of the UC1526 are designed to source and sink 100mA continuously and 200mA peak. Loads can be driven either from the output pins 13 and 16, or from the +Vc, as required.

Since the bottom transistor of the totem-pole is allowed to saturate, there is a momentary conduction path from the +Vc terminal to ground during switching. To limit the resulting current spikes a small resistor in series with pin 14 is always recommended. The resistor value is determined by the driver supply voltage, and should be chosen for 200mA peak currents.

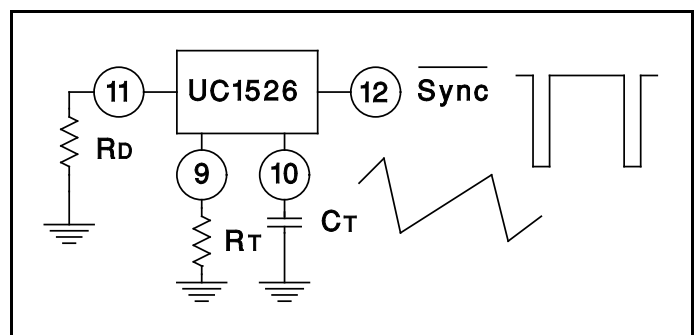

Figure 5. Oscillator Connections and Waveforms

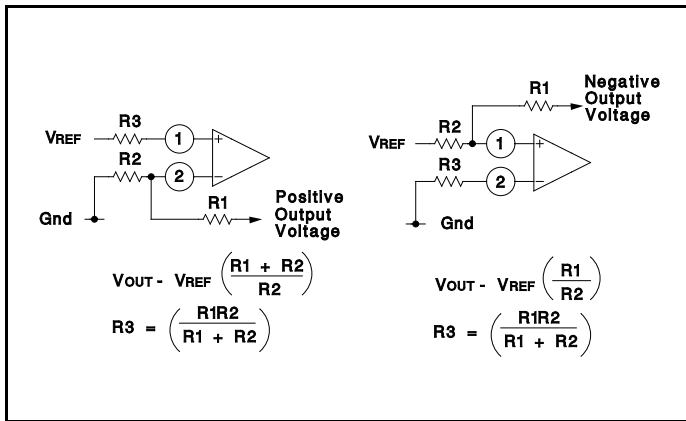

Figure 6. Error Amplifier Connections

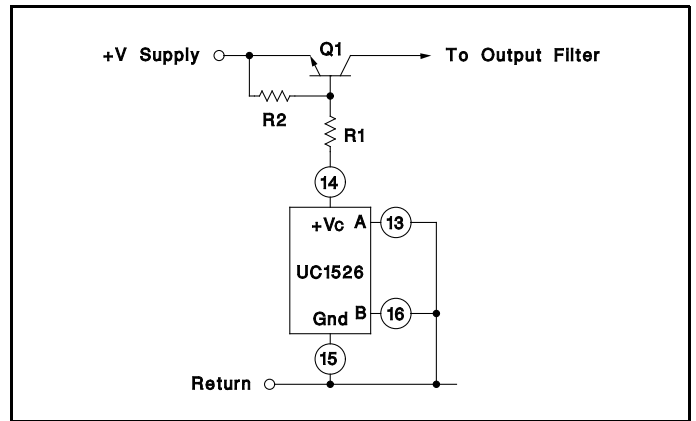

Figure 8. Single-Ended Configuration

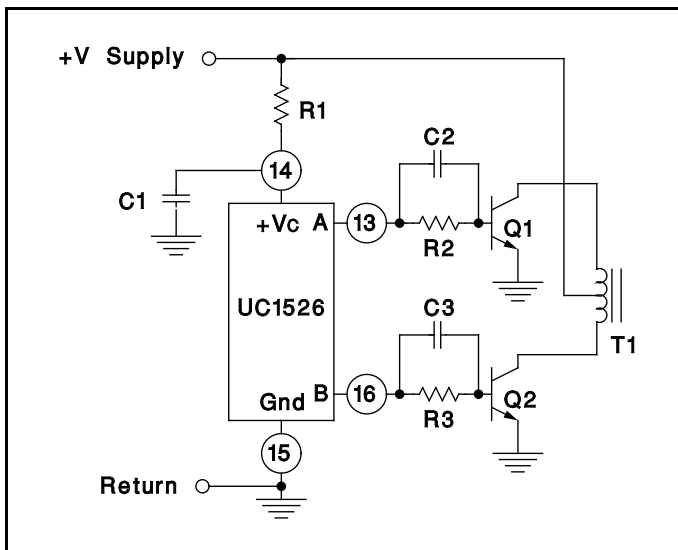

Figure 7. Push-Pull Configuration

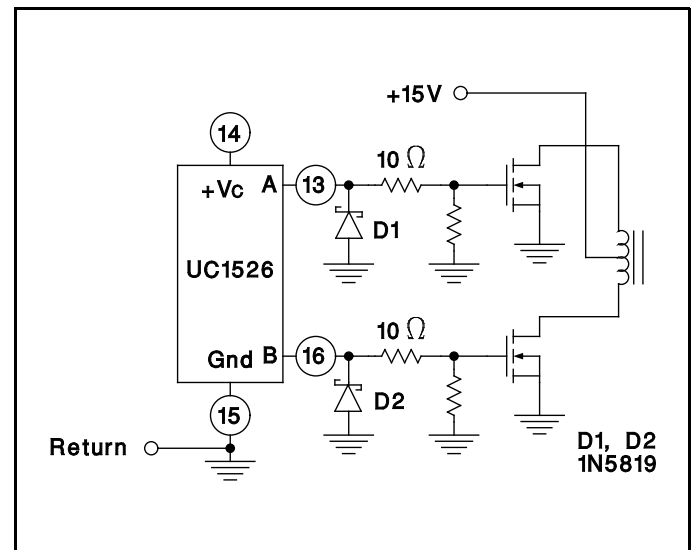
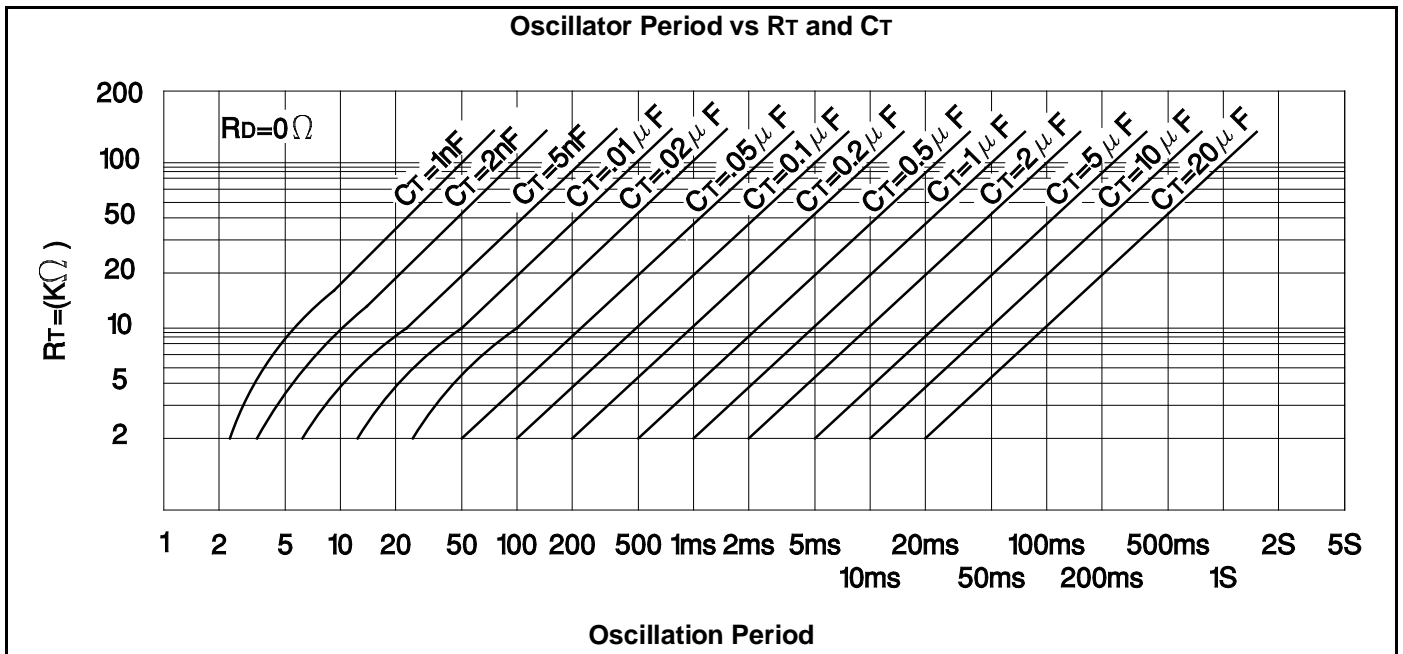
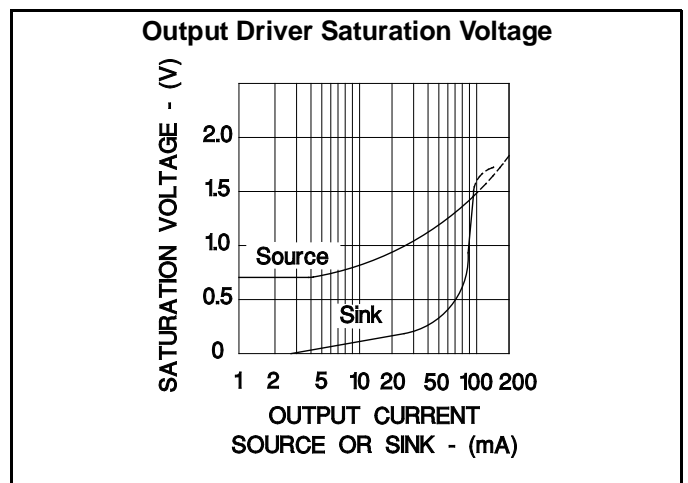
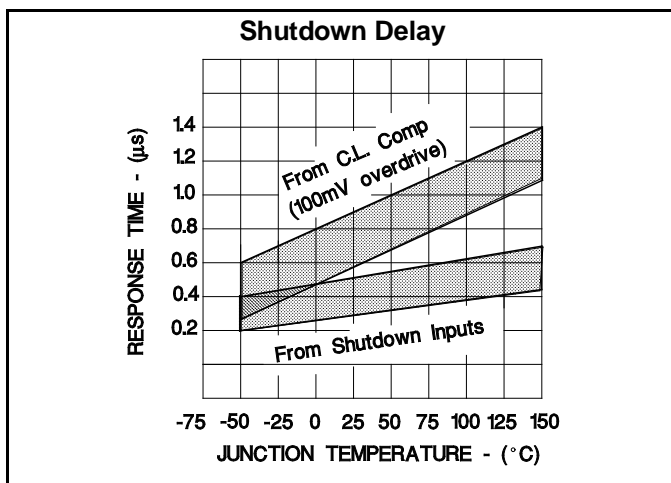
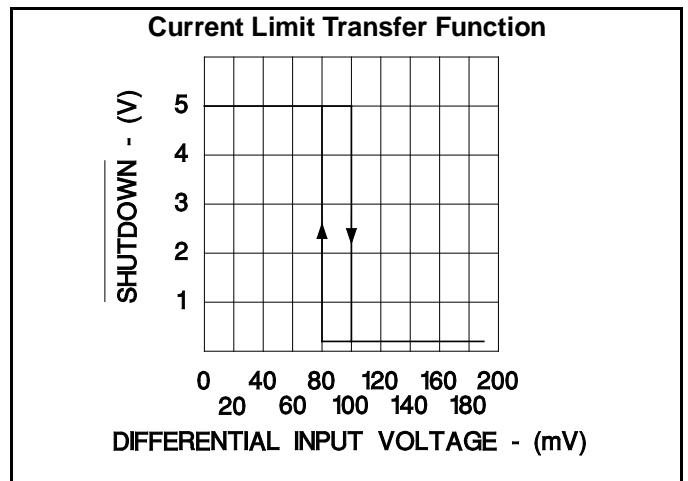
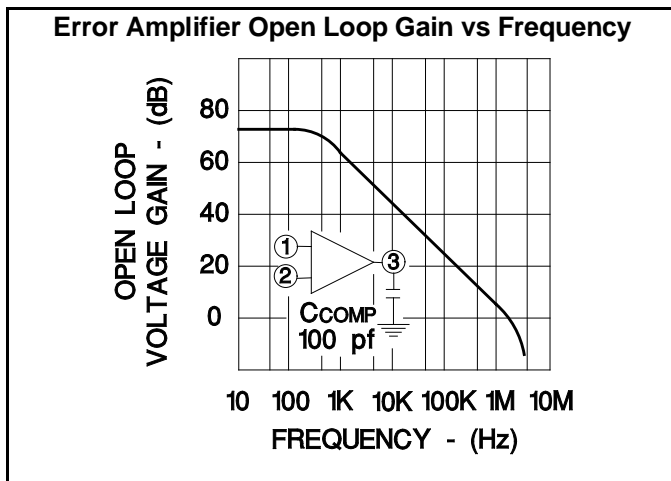
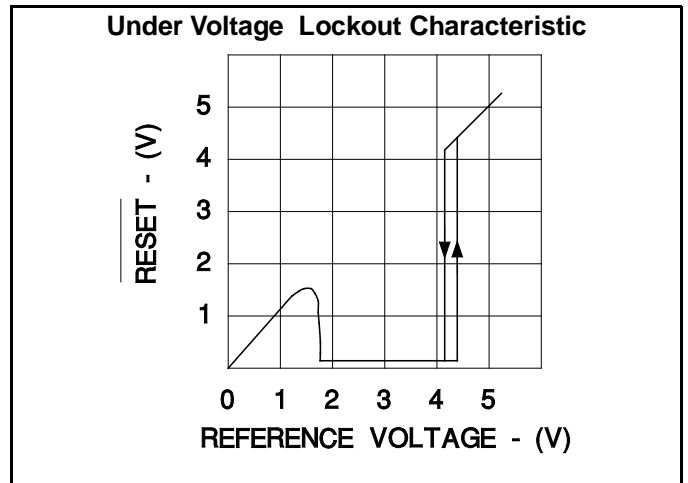
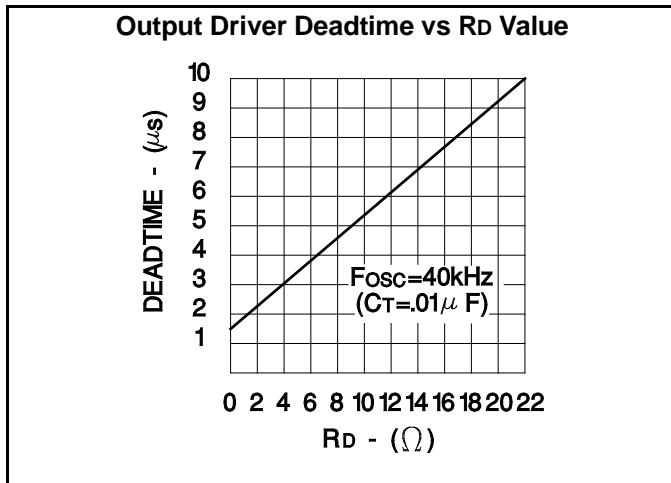

Figure 9. Driving N-channel Power Mosfets

## TYPICAL CHARACTERISTICS



TYPICAL CHARACTERISTICS



In no event shall TI's liability arising out of such information exceed the total purchase price of the TI part(s) at issue in this document sold by TI to Customer on an annual basis.



**PACKAGING INFORMATION**

Orderable Device	Status <sup>(1)</sup>	Package Type	Package Drawing	Pins	Package Qty	Eco Plan <sup>(2)</sup>	Lead/Ball Finish	MSL Peak Temp <sup>(3)</sup>
85515012A	ACTIVE	LCCC	FK	20	1	TBD	POST-PLATE	N / A for Pkg Type
8551501VA	ACTIVE	CDIP	J	18	1	TBD	A42 SNPB	N / A for Pkg Type
UC1526J	ACTIVE	CDIP	J	18	1	TBD	A42 SNPB	N / A for Pkg Type
UC1526J883B	ACTIVE	CDIP	J	18	1	TBD	A42 SNPB	N / A for Pkg Type
UC1526L	ACTIVE	LCCC	FK	20	1	TBD	POST-PLATE	N / A for Pkg Type
UC1526L883B	ACTIVE	LCCC	FK	20	1	TBD	POST-PLATE	N / A for Pkg Type
UC2526AJ	ACTIVE	CDIP	J	18	1	TBD	A42 SNPB	N / A for Pkg Type
UC2526N	ACTIVE	PDIP	N	18	20	Green (RoHS & no Sb/Br)	CU NIPDAU	N / A for Pkg Type
UC2526NG4	ACTIVE	PDIP	N	18	20	Green (RoHS & no Sb/Br)	CU NIPDAU	N / A for Pkg Type
UC3526AJ	ACTIVE	CDIP	J	18	1	TBD	A42 SNPB	N / A for Pkg Type
UC3526DW	ACTIVE	SOIC	DW	18	40	Green (RoHS & no Sb/Br)	CU NIPDAU	Level-2-260C-1 YEAR
UC3526DWG4	ACTIVE	SOIC	DW	18	40	Green (RoHS & no Sb/Br)	CU NIPDAU	Level-2-260C-1 YEAR
UC3526DWTR	ACTIVE	SOIC	DW	18	2000	Green (RoHS & no Sb/Br)	CU NIPDAU	Level-2-260C-1 YEAR
UC3526DWTRG4	ACTIVE	SOIC	DW	18	2000	Green (RoHS & no Sb/Br)	CU NIPDAU	Level-2-260C-1 YEAR
UC3526N	ACTIVE	PDIP	N	18	20	Green (RoHS & no Sb/Br)	CU NIPDAU	N / A for Pkg Type
UC3526NG4	ACTIVE	PDIP	N	18	20	Green (RoHS & no Sb/Br)	CU NIPDAU	N / A for Pkg Type

<sup>(1)</sup> The marketing status values are defined as follows:

**ACTIVE:** Product device recommended for new designs.

**LIFEBUY:** TI has announced that the device will be discontinued, and a lifetime-buy period is in effect.

**NRND:** Not recommended for new designs. Device is in production to support existing customers, but TI does not recommend using this part in a new design.

**PREVIEW:** Device has been announced but is not in production. Samples may or may not be available.

**OBsolete:** TI has discontinued the production of the device.

<sup>(2)</sup> Eco Plan - The planned eco-friendly classification: Pb-Free (RoHS), Pb-Free (RoHS Exempt), or Green (RoHS & no Sb/Br) - please check <http://www.ti.com/productcontent> for the latest availability information and additional product content details.

**TBD:** The Pb-Free/Green conversion plan has not been defined.

**Pb-Free (RoHS):** TI's terms "Lead-Free" or "Pb-Free" mean semiconductor products that are compatible with the current RoHS requirements for all 6 substances, including the requirement that lead not exceed 0.1% by weight in homogeneous materials. Where designed to be soldered at high temperatures, TI Pb-Free products are suitable for use in specified lead-free processes.

**Pb-Free (RoHS Exempt):** This component has a RoHS exemption for either 1) lead-based flip-chip solder bumps used between the die and package, or 2) lead-based die adhesive used between the die and leadframe. The component is otherwise considered Pb-Free (RoHS compatible) as defined above.

**Green (RoHS & no Sb/Br):** TI defines "Green" to mean Pb-Free (RoHS compatible), and free of Bromine (Br) and Antimony (Sb) based flame retardants (Br or Sb do not exceed 0.1% by weight in homogeneous material)

<sup>(3)</sup> MSL, Peak Temp. -- The Moisture Sensitivity Level rating according to the JEDEC industry standard classifications, and peak solder temperature.

**Important Information and Disclaimer:** The information provided on this page represents TI's knowledge and belief as of the date that it is provided. TI bases its knowledge and belief on information provided by third parties, and makes no representation or warranty as to the accuracy of such information. Efforts are underway to better integrate information from third parties. TI has taken and continues to take reasonable steps to provide representative and accurate information but may not have conducted destructive testing or chemical analysis on

incoming materials and chemicals. TI and TI suppliers consider certain information to be proprietary, and thus CAS numbers and other limited information may not be available for release.

In no event shall TI's liability arising out of such information exceed the total purchase price of the TI part(s) at issue in this document sold by TI to Customer on an annual basis.

**OTHER QUALIFIED VERSIONS OF UC1526, UC2526, UC2526AM, UC3526, UC3526AM :**

- Catalog: [UC2526A](#), [UC3526M](#), [UC3526A](#)
- Military: [UC2526M](#), [UC1526A](#)

**NOTE: Qualified Version Definitions:**

- Catalog - TI's standard catalog product
- Military - QML certified for Military and Defense Applications

**TAPE AND REEL INFORMATION**



**QUADRANT ASSIGNMENTS FOR PIN 1 ORIENTATION IN TAPE**



\*All dimensions are nominal

Device	Package Type	Package Drawing	Pins	SPQ	Reel Diameter (mm)	Reel Width W1 (mm)	A0 (mm)	B0 (mm)	K0 (mm)	P1 (mm)	W (mm)	Pin1 Quadrant
UC3526DWTR	SOIC	DW	18	2000	330.0	24.4	10.9	12.0	2.7	12.0	24.0	Q1

**TAPE AND REEL BOX DIMENSIONS**



\*All dimensions are nominal

Device	Package Type	Package Drawing	Pins	SPQ	Length (mm)	Width (mm)	Height (mm)
UC3526DWTR	SOIC	DW	18	2000	346.0	346.0	41.0

## IMPORTANT NOTICE

Texas Instruments Incorporated and its subsidiaries (TI) reserve the right to make corrections, modifications, enhancements, improvements, and other changes to its products and services at any time and to discontinue any product or service without notice. Customers should obtain the latest relevant information before placing orders and should verify that such information is current and complete. All products are sold subject to TI's terms and conditions of sale supplied at the time of order acknowledgment.

TI warrants performance of its hardware products to the specifications applicable at the time of sale in accordance with TI's standard warranty. Testing and other quality control techniques are used to the extent TI deems necessary to support this warranty. Except where mandated by government requirements, testing of all parameters of each product is not necessarily performed.

TI assumes no liability for applications assistance or customer product design. Customers are responsible for their products and applications using TI components. To minimize the risks associated with customer products and applications, customers should provide adequate design and operating safeguards.

TI does not warrant or represent that any license, either express or implied, is granted under any TI patent right, copyright, mask work right, or other TI intellectual property right relating to any combination, machine, or process in which TI products or services are used. Information published by TI regarding third-party products or services does not constitute a license from TI to use such products or services or a warranty or endorsement thereof. Use of such information may require a license from a third party under the patents or other intellectual property of the third party, or a license from TI under the patents or other intellectual property of TI.

Reproduction of TI information in TI data books or data sheets is permissible only if reproduction is without alteration and is accompanied by all associated warranties, conditions, limitations, and notices. Reproduction of this information with alteration is an unfair and deceptive business practice. TI is not responsible or liable for such altered documentation. Information of third parties may be subject to additional restrictions.

Resale of TI products or services with statements different from or beyond the parameters stated by TI for that product or service voids all express and any implied warranties for the associated TI product or service and is an unfair and deceptive business practice. TI is not responsible or liable for any such statements.

TI products are not authorized for use in safety-critical applications (such as life support) where a failure of the TI product would reasonably be expected to cause severe personal injury or death, unless officers of the parties have executed an agreement specifically governing such use. Buyers represent that they have all necessary expertise in the safety and regulatory ramifications of their applications, and acknowledge and agree that they are solely responsible for all legal, regulatory and safety-related requirements concerning their products and any use of TI products in such safety-critical applications, notwithstanding any applications-related information or support that may be provided by TI. Further, Buyers must fully indemnify TI and its representatives against any damages arising out of the use of TI products in such safety-critical applications.

TI products are neither designed nor intended for use in military/aerospace applications or environments unless the TI products are specifically designated by TI as military-grade or "enhanced plastic." Only products designated by TI as military-grade meet military specifications. Buyers acknowledge and agree that any such use of TI products which TI has not designated as military-grade is solely at the Buyer's risk, and that they are solely responsible for compliance with all legal and regulatory requirements in connection with such use.

TI products are neither designed nor intended for use in automotive applications or environments unless the specific TI products are designated by TI as compliant with ISO/TS 16949 requirements. Buyers acknowledge and agree that, if they use any non-designated products in automotive applications, TI will not be responsible for any failure to meet such requirements.

Following are URLs where you can obtain information on other Texas Instruments products and application solutions:

### Products

Amplifiers	<a href="http://amplifier.ti.com">amplifier.ti.com</a>
Data Converters	<a href="http://dataconverter.ti.com">dataconverter.ti.com</a>
DSP	<a href="http://dsp.ti.com">dsp.ti.com</a>
Clocks and Timers	<a href="http://www.ti.com/clocks">www.ti.com/clocks</a>
Interface	<a href="http://interface.ti.com">interface.ti.com</a>
Logic	<a href="http://logic.ti.com">logic.ti.com</a>
Power Mgmt	<a href="http://power.ti.com">power.ti.com</a>
Microcontrollers	<a href="http://microcontroller.ti.com">microcontroller.ti.com</a>
RFID	<a href="http://www.ti-rfid.com">www.ti-rfid.com</a>
RF/IF and ZigBee® Solutions	<a href="http://www.ti.com/lprf">www.ti.com/lprf</a>

### Applications

Audio	<a href="http://www.ti.com/audio">www.ti.com/audio</a>
Automotive	<a href="http://www.ti.com/automotive">www.ti.com/automotive</a>
Broadband	<a href="http://www.ti.com/broadband">www.ti.com/broadband</a>
Digital Control	<a href="http://www.ti.com/digitalcontrol">www.ti.com/digitalcontrol</a>
Medical	<a href="http://www.ti.com/medical">www.ti.com/medical</a>
Military	<a href="http://www.ti.com/military">www.ti.com/military</a>
Optical Networking	<a href="http://www.ti.com/opticalnetwork">www.ti.com/opticalnetwork</a>
Security	<a href="http://www.ti.com/security">www.ti.com/security</a>
Telephony	<a href="http://www.ti.com/telephony">www.ti.com/telephony</a>
Video & Imaging	<a href="http://www.ti.com/video">www.ti.com/video</a>
Wireless	<a href="http://www.ti.com/wireless">www.ti.com/wireless</a>

Mailing Address: Texas Instruments, Post Office Box 655303, Dallas, Texas 75265  
Copyright © 2008, Texas Instruments Incorporated